

Beaumont Environmental Systems

Evaporative Cooling System

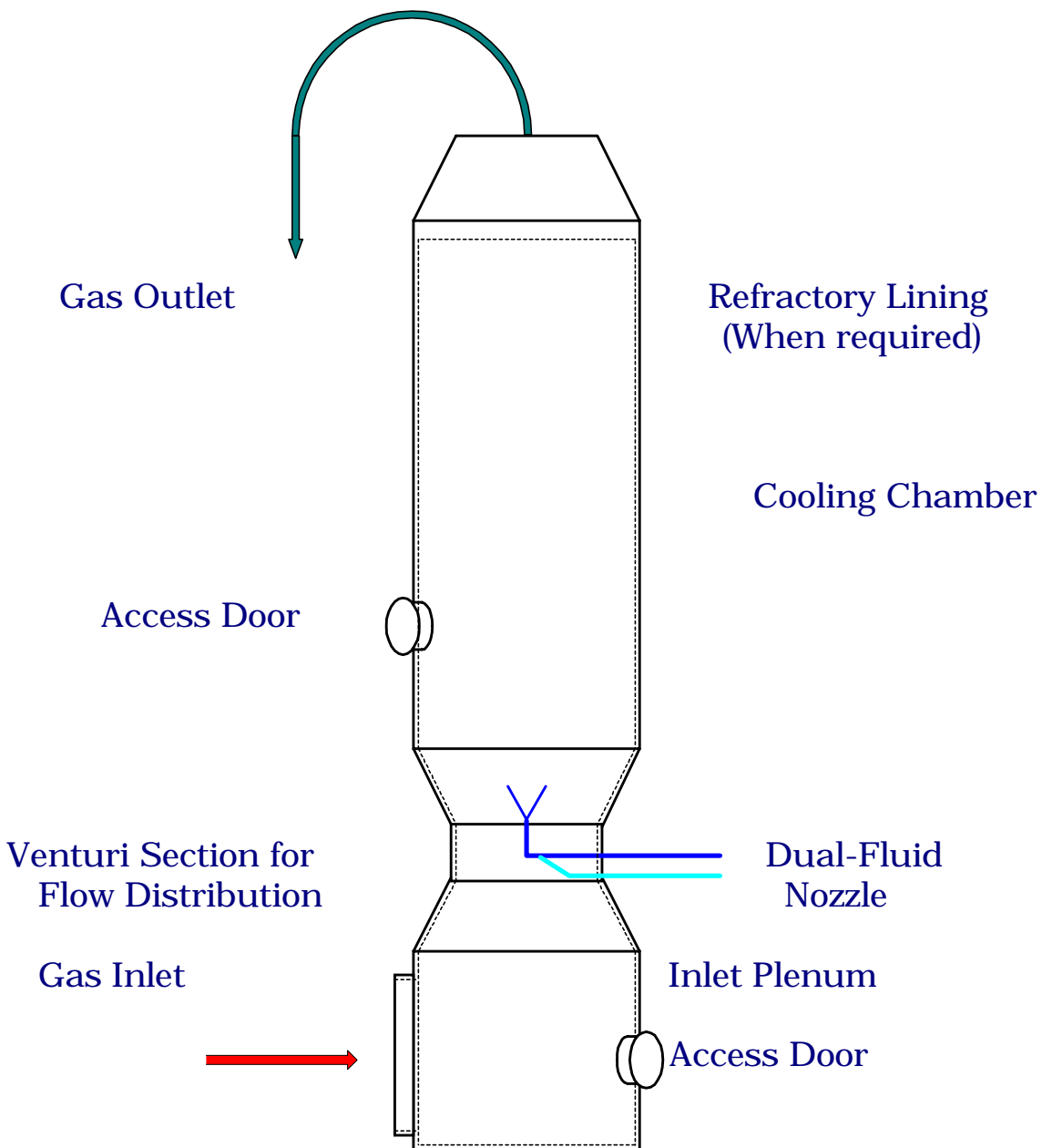

Beaumont Environmental Systems personnel have in-depth expertise in the design and application of all types of hot gas cooling systems gained from their years of experience in servicing the melting and combustion industries. No one type of cooling system will be the most economical approach to a project. By combining different cooling methods the most economical approach,

may be determined. The various methods of hot gas cooling are normally (economically) limited by the temperature range to be cooled. Beaumont Environmental Systems has the ability, developed through many years of experience to utilize the least cost combination of hot gas cooling methods to provide a client with the most suitable solution to his project needs.

Beaumont Environmental Systems

Spray Cooler Experience

The major design criteria to successfully design an evaporative spray cooler is to control the water droplet diameter, vessel velocity, vessel retention time, nozzle selection, available water evaporation driving force, ensure no wetting of the vessel walls and consideration of the resulting water dew point and its potential effects on downstream equipment. This method of cooling is economically utilized for gas temperature ranges from 2500° F+ cooled to 400 to 500° F. These design criteria were successfully utilized in the design of the following projects. It should also be recognized that the successful design of wet/dry SO₂ removal systems requires the similar expertise as in the design of spray cooler systems

Specific Projects

The following systems incorporate two fluid nozzles, that are commercially available, to achieve the gas cooling requirements.

Kelsey-Hayes, Detroit, Michigan

108" Diameter Iron Cupola supplied with evaporative spray cooler, ductwork, fans, fabric filter and controls. Cooled gases from 2200° F to 500° F in refractory lined cooler vessel using high pressure water sprays. Included construction.

Great Lakes Steel, Wyandotte, Michigan

Two (2) 20'-0" diameter Electric Arc Furnaces, supplied with evaporative spray cooler water cooled duct, furnace controls, ductwork, fans, fabric filter and system controls. Cooled gases from 1200° F to 500° F in water-cooled shell cooler vessel using dual fluid water sprays. Included construction and all water feed and drain piping.

Bethlehem Steel, Steelton, Pennsylvania

Two (2) 22'-0" diameter Electric Arc Furnaces supplied with evaporative spray cooler water cooled duct, furnace controls, ductwork, fans, fabric filter and system controls. Cooled gases from 1200° F to 500° F in water cooled shell cooler vessel using dual fluid water sprays.

New England Malleable, Warwick, RI

56 " diameter Iron Cupola supplied with high pressure spray evaporative cooler and fabric filter.

McCauley Foundry, San Francisco, CA

Small Iron Cupola supplied with high-pressure spray evaporative cooler and fabric filter.

Cement Kiln Projects

Dual fluid spray nozzle type spray coolers for two (2) cement kiln projects. The gases are cooled from 1200° F to 500° F. Projects typically have included evaporative spray cooler and fabric filter.

Air to Air Heat Exchanger Experience

Air to air heat exchangers has been applied to numerous projects; to many to list separately. Radiant U-Tube type coolers and forced draft type heat exchangers have been utilized in the steel, iron, cement and related industries for many years. The number of projects exceed seventy-five of various sizes.

U-tube type heat exchangers are designed and engineered directly by BES personnel. Forced draft type heat exchangers are normally specified and purchased from various specialty suppliers. This method of cooling is best economically utilized for gas temperature ranges from 1200° F+ to 400° F.

Water Cooled Duct Experience

Water-cooled ductwork has been applied to numerous steel furnaces. BES personnel have the ability to design and engineer double walled water-cooled duct. Tube type water-cooled duct is specified and purchased from specialty suppliers for economical reasons. This method of cooling is best economically utilized for gas temperature ranges from 2500° F+ to 1200° F.

Dilution Air Cooling Experience

This most widely cooling method is applied in many industries and utilizes the inducement of ambient or other cooler air into the hot gas stream for cooling purposes.

BES personnel have utilized this cooling method in numerous applications and industries. The use of the proper in-draft velocity and placement of the dilution air damper is important to the system operation, eliminating the potential of inducing rain and optimum cooling efficiency.

This method of cooling is best economically utilized for gas temperature ranges from 400 to 500° F to 260° F or less.

Beaumont Environmental Systems

Wet Spray Tower Absorber

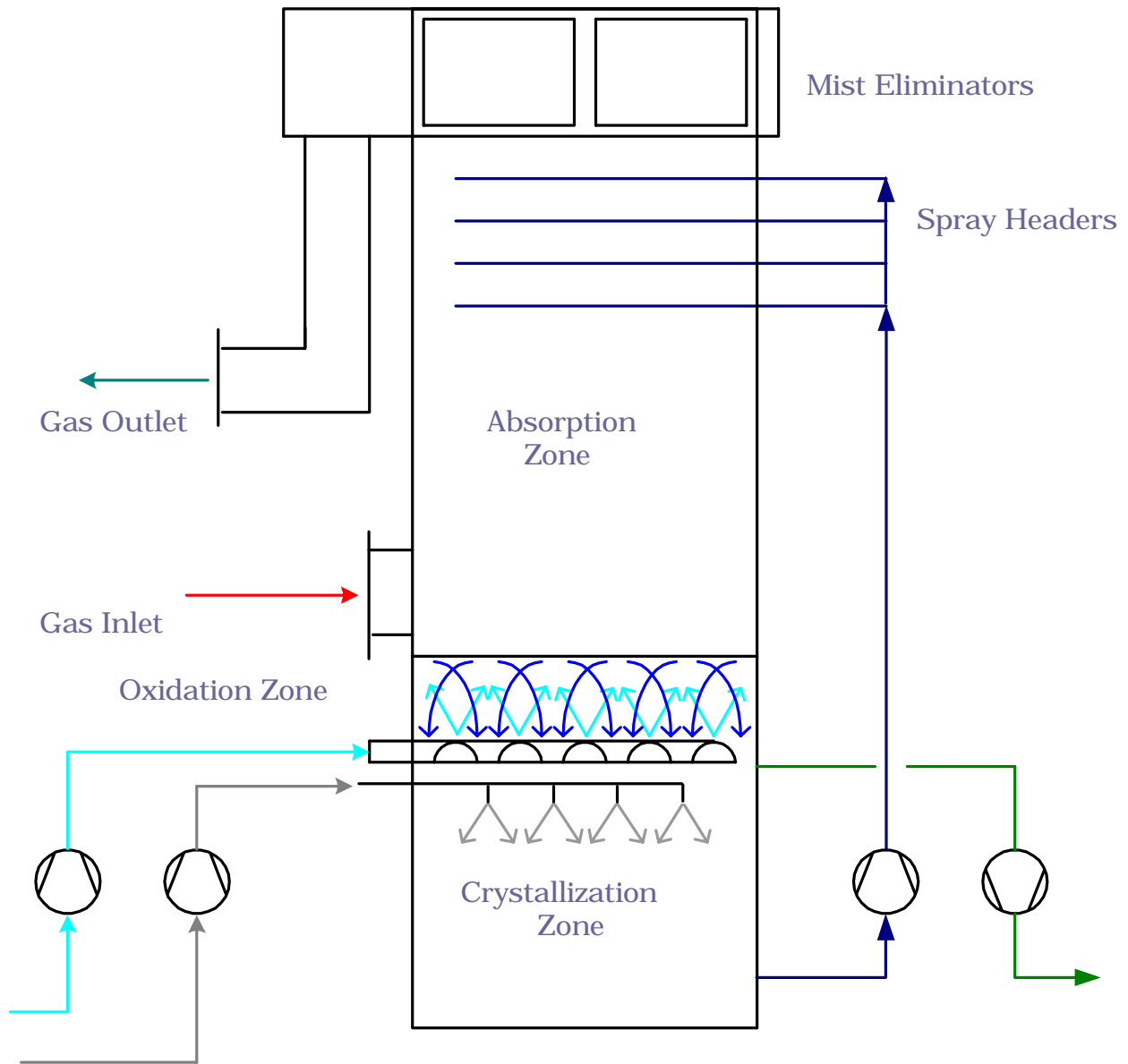

Wet Spray Tower Absorber for Acid Gas Cleaning

Beaumont Environmental Systems

Wet Spray Tower Absorber

- 1 Gas Inlet
- 2 Gas Outlet
- 3 Oxidation Air Supply
- 4 Lime Slurry
- 5 Spent Slurry to Dewatering
- 6 Mist Eliminator Wash
- 7 Absorber Drain
- 8 Absorber Recycle

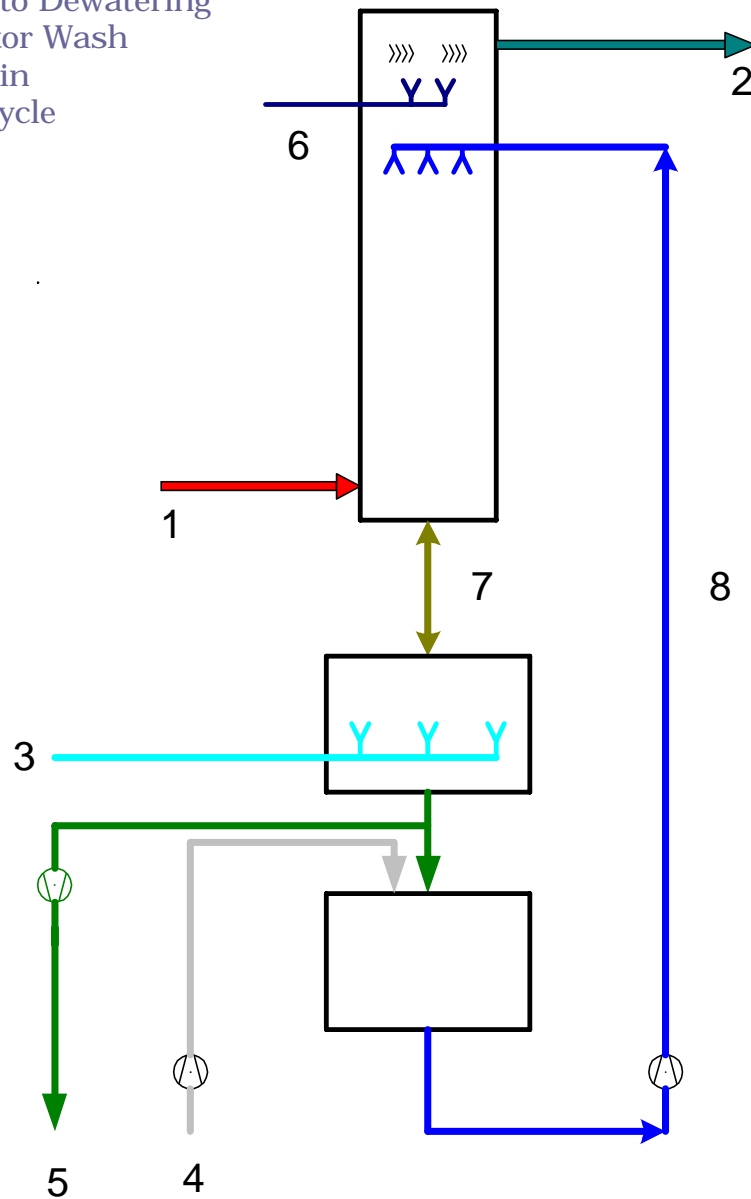

Wet Spray Tower Absorber for Acid Gas Cleaning

Beaumont Environmental Systems

Packed Tower Absorber

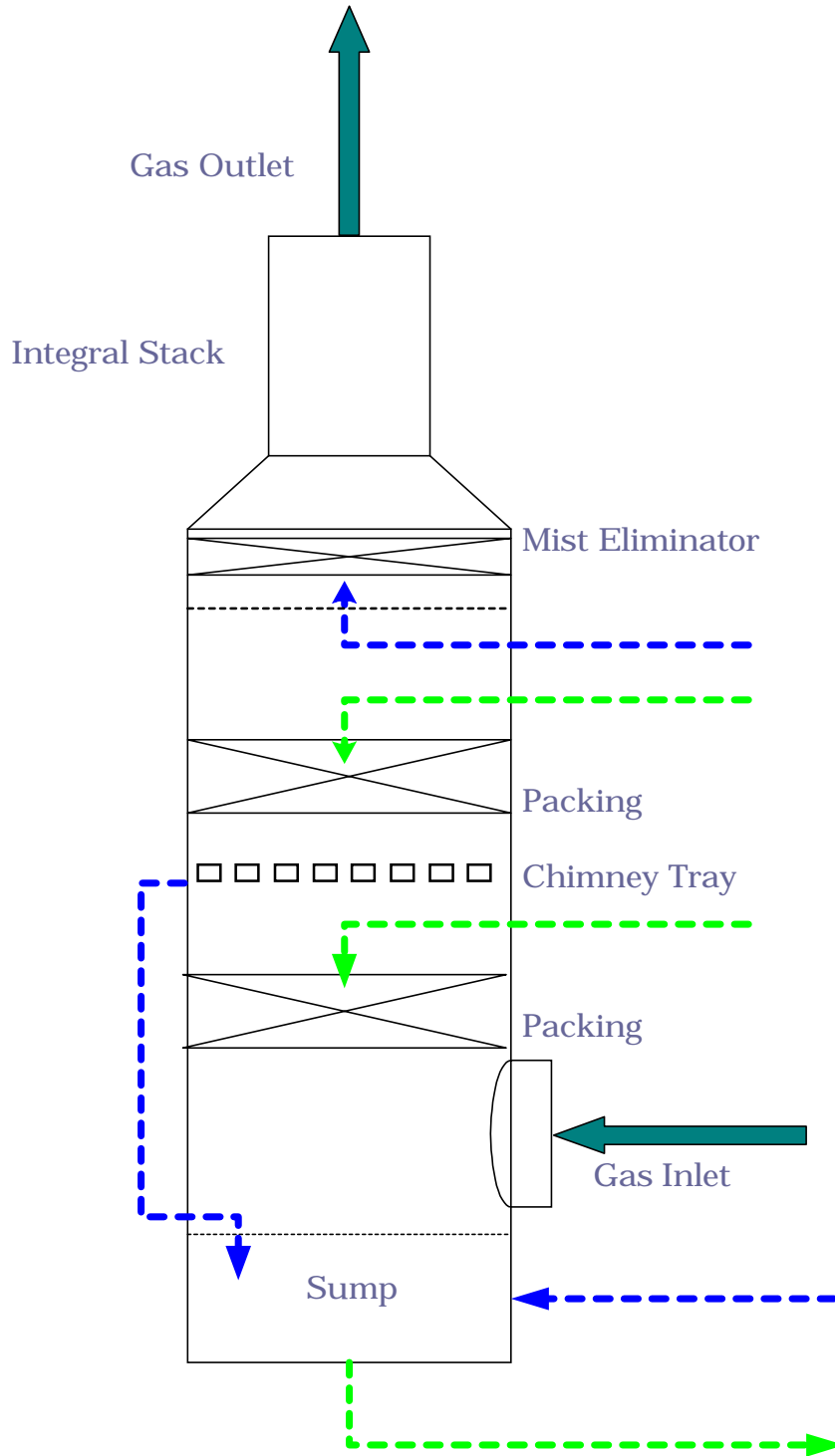

Wet Scrubber for NO_x Cleaning

Beaumont Environmental Systems

Packed Tower Absorber

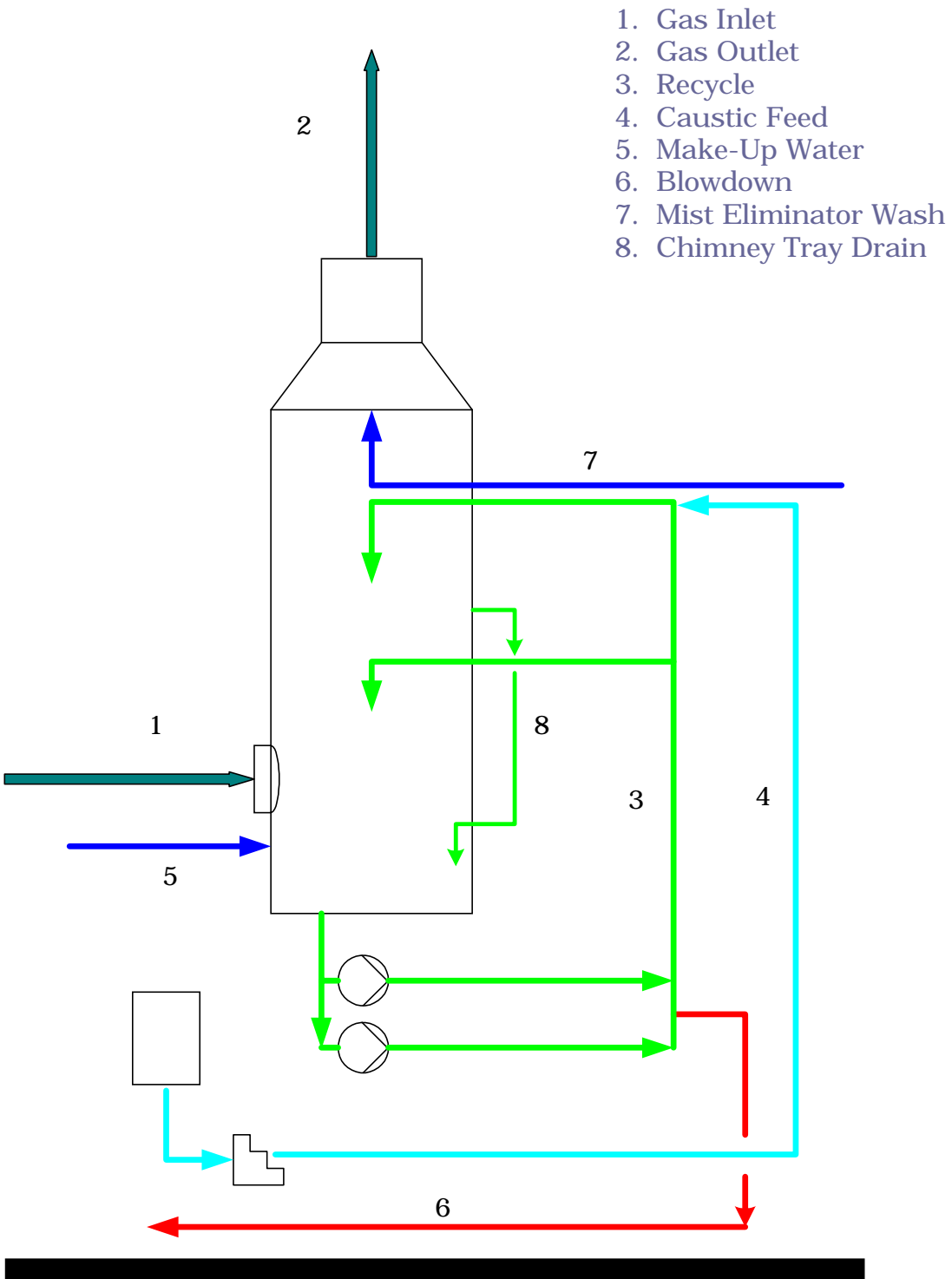

Packed Tower Absorber